



*A name you can trust*

**LINE  
AGRAR**

**DEUTSCH**



A NAME

YOU CAN

TRUST



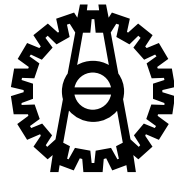

# INDEX

4

## ABOUT US

UNSERE GESCHICHTE,  
UNSERE WERTE

14

## MULCHER

FÜR PARK, GRÜNFLÄCHEN  
LEICHTE VEGETATION

20

## MULCHERÄTE

FÜR WEIN- UND  
OBSTGÄRTEN

36

## SICHELMUCHER

FÜR WEIN-  
UND OBSTBAU

42

## ZWISCHENREIHEN- UND

UNKRAUTMÄHER

62

**SPEZIALMULCHER**

MIT PICK-UP ROTOR FÜR  
BESCHNEIDUNGSRESTE

72

**MULCHER**

FÜR GRÜNFLÄCHEN, BRACHEN,  
STÄRKEN BEWUCHS

84

**HOCHRAHMEN-  
MÄHER**

FÜR MAISSTÄNGEL, STROH

92

**BÖSCHUNGS-  
MULCHER**

FÜR BÖSCHUNGEN UND GRÄBEN

104

**FORST-MULCHER**

FÜR BRACHLANDPFLEGE, ÄSTEN  
UND STÄMME

114

**KREISELKETTEN-  
MÄHER**

120

**HYDRAULISCHE  
AUSLEGERSMÄHER**

136

**STEINVERGRÄBER  
UMERKEHRFRÄSE**

144

**BODENFRÄSE**

160

**KREISELEGGEN**





# MISSION UND WERTE

**Qualität, Widerstandsfähigkeit und Zuverlässigkeit: die Grundpfeiler unserer Arbeit.**

Unsere Mission ist es, robuste und langlebige Geräte anzubieten, die so konzipiert sind, dass sie das Bruchrisiko minimieren und stets maximale Effizienz im Einsatz gewährleisten.

Wir sind eine Familie, die auf Werte, wie Zusammenarbeit und Vertrauens zählt. Jeden Tag stellen wir mit Leidenschaft und

Engagement Hunderte von Geräten her, die auf die tatsächlichen Bedürfnisse derjenigen zugeschnitten sind, die damit arbeiten. Geleitet von einem starken Sinn für Ethik und der Verantwortung die für jeden Kunden passende Lösung zu finden, befolgen wir strikt die höchsten Qualitätsstandards.

Entschlossen und voller Energie blicken wir in die Zukunft, bereit uns ständig weiterzuentwickeln, um Ihnen stets mit Produkten zur Seite zu stehen, die einen Mehrwert darstellen.

# SEIT 1920

## AUF DEM FELD AN IHRER SEITE

1920

Start der Tätigkeiten

1959

Umzug nach Caldiero

1972

Mulchgeräte für Böschungen

1979

Mulchgeräte für Traktoren

1989

Hydraulische Böschungsmäher für Bagger

1995

Sichelmähersortiment



2003

Picker-Sortiment

2005

Erweiterung der Ersatzteilabteilung

2024

130.000 verkaufte Maschinen

2002

Böschungsmäherausleger für Traktor

2013

Ecosprint Spaliermulcher

2018

Neue Produktionsstätte



# LANGLEBIGE ANBAUGERÄTE

Jede Maschine von Berti ist das Ergebnis eines Prozesses, der mit einer Idee beginnt und in unseren Werken Gestalt annimmt und das seit über 60 Jahren.

Es geht nicht nur darum, Maschinen zu bauen, **sondern Lösungen zu finden**, die für diejenigen gedacht sind, **die täglich auf den Feldern arbeiten** und sich immer neuen Herausforderungen stellen müssen.

Von der Bearbeitung der Gehäuse über das Auswuchten der

Rotoren – das Aushängeschild unserer Produktion – bis hin zum Spachteln, Lackieren, Montieren und Verpacken wird jeder Schritt mit Sorgfalt und Präzision ausgeführt, die das Ergebnis **jahrzehntelanger** Erfahrung sind.

Unsere Aufmerksamkeit beschränkt sich nicht nur auf das, was sofort sichtbar ist: Auch die verstecktesten Komponenten werden mit der gleichen Sorgfalt bearbeitet und behandelt, denn wir wissen, dass **Details den Unterschied ausmachen**.

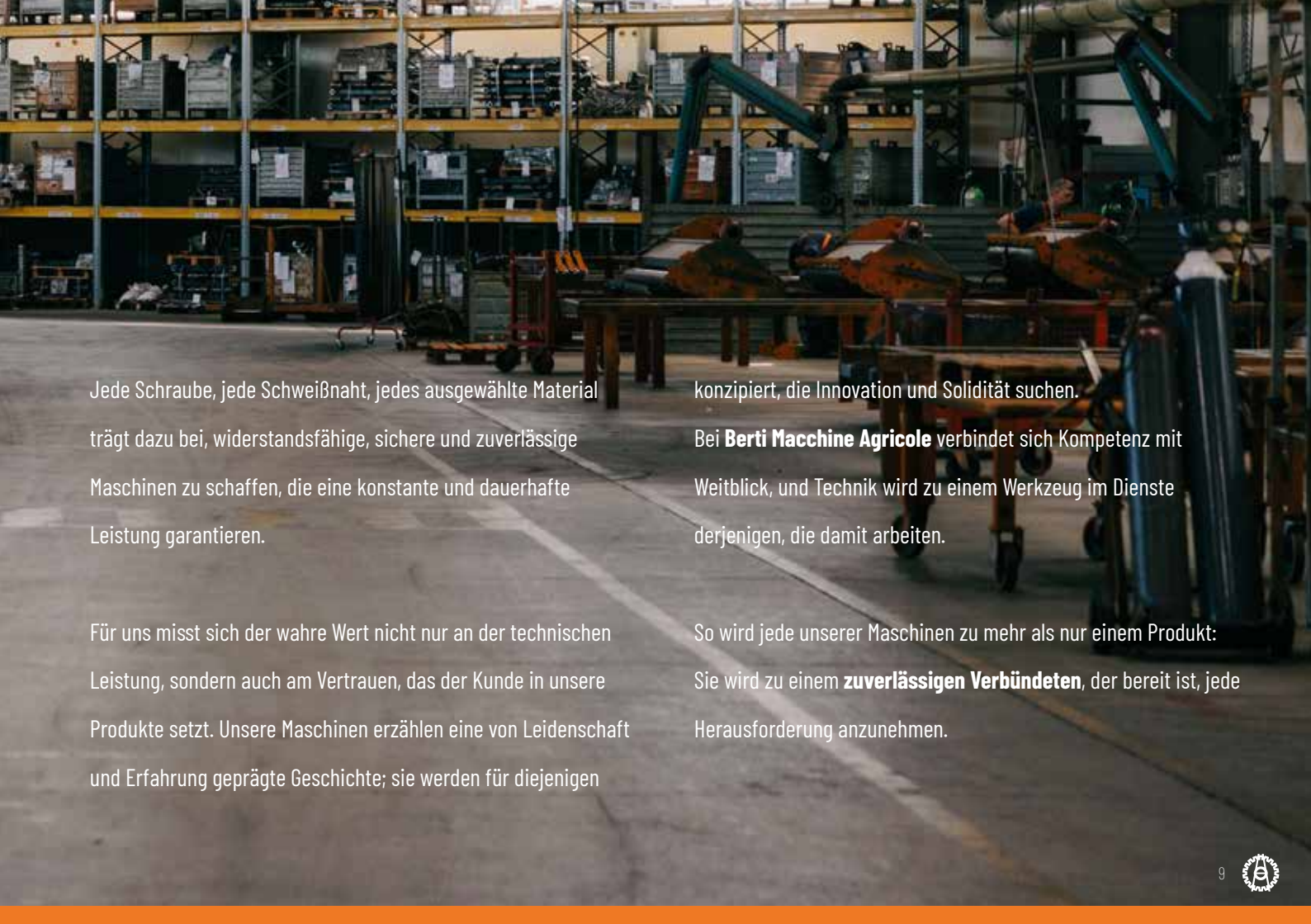

Jede Schraube, jede Schweißnaht, jedes ausgewählte Material trägt dazu bei, widerstandsfähige, sichere und zuverlässige Maschinen zu schaffen, die eine konstante und dauerhafte Leistung garantieren.

Für uns misst sich der wahre Wert nicht nur an der technischen Leistung, sondern auch am Vertrauen, das der Kunde in unsere Produkte setzt. Unsere Maschinen erzählen eine von Leidenschaft und Erfahrung geprägte Geschichte; sie werden für diejenigen

konzipiert, die Innovation und Solidität suchen.

Bei **Berti Macchine Agricole** verbindet sich Kompetenz mit Weitblick, und Technik wird zu einem Werkzeug im Dienste derjenigen, die damit arbeiten.

So wird jede unserer Maschinen zu mehr als nur einem Produkt: Sie wird zu einem **zuverlässigen Verbündeten**, der bereit ist, jede Herausforderung anzunehmen.

# NACHHALTIGKEIT UND ZERTIFIZIERUNGEN

Unser tägliches Engagement für die **Qualität unserer Produkte**, die **Sicherheit unserer Mitarbeiter** und den **Schutz der Umwelt** ist nach den höchsten internationalen Standards zertifiziert.

Im Hinblick auf eine nachhaltige Entwicklung haben wir konkrete Entscheidungen getroffen: Zum Beispiel können wir dank unserer **Photovoltaikanlage**, saubere Energie produzieren und speichern und so die Umweltbelastung unseres Werks reduzieren.

Auch in der Endbearbeitung zeigen wir unser Engagement für

die Umwelt mit einer **Lackieranlage auf Wasserbasis**, die die Emission flüchtiger organischer Verbindungen (VOC) im Vergleich zu herkömmlichen Lösungsmittelsystemen deutlich reduziert.

**Für uns sind Innovation und Nachhaltigkeit untrennbar miteinander verbunden.**

**Wir arbeiten jeden Tag an einer verantwortungsbewussteren Zukunft.**





Sicherheit und Gesundheit der Arbeitnehmer



Umweltschutz



Qualitätssystem

**+1200**

CO<sup>2</sup>-Ausstoss in Tonnen/Jahr, die nicht in die Luft abgegeben werden

**+118 KW/h**

Erzeugt von der unternehmenseigenen Photovoltaikanlage

**12050 KG**

VOC, die dank der Verwendung von Lacken auf Wasserbasis im 2024 nicht ausgestossen werden



# AFTER-SALES-SERVICE UND ERSATZTEILE

Unsere Beziehung zum Kunden endet nicht mit dem Verkauf:

Ganz im Gegenteil, ist das nur der Beginn einer **langfristigen Zusammenarbeit**. Wir glauben, dass die Zuverlässigkeit eines Unternehmens auch daran gemessen wird, wie es den Kunden nach dem Kauf unterstützt.

Aus diesem Grund haben wir einen **soliden After-Sales-Service** aufgebaut, der auf technischer Kompetenz, Verfügbarkeit und Zuhören basiert.

Jede **Serviceanfrage** wird umgehend und sorgfältig bearbeitet, um sicherzustellen, dass die **Maschinen** so schnell wie möglich

**wieder einsatzbereit** sind.

Wir bieten ein komplettes Sortiment an Ersatzteilen, die für konstante Leistung und lange Lebensdauer entwickelt und getestet wurden.

Jeder Kontakt, jede Antwort, jeder Einsatz spiegelt unsere Philosophie wider: **ein zuverlässiger Partner zu sein, der denjenigen, die täglich auf den Feldern arbeiten, Kontinuität und Sicherheit garantiert.**

11

Zuständige für den After-Sales-Service und die Ersatzteile

675 M<sup>2</sup>

Bereich Ersatzteilmagazin

48H

Bearbeitung von Anfragen

1

Kundenportal: My Berti

2

Vertikale Magazine

+6500

Speditionen/Jahr

# MULCHER

FÜR PARKS, GRÜNFLÄCHEN, LEICHTE VEGETATION



# MINI



15-30 CV



Ø 2 cm



	MINI 115		MINI 125		MINI 145	
Arbeitsbreite (cm)	115		125		145	
Schlegel G	32		34		40	
Seitenverschiebung (mm)	530	620	530	720	615	835
Gewicht min-max (Kg)	200	200	205	260	220	280

# GREEN



25-60 CV



Ø 2-3 cm



**HARDOX®**

	GREEN 115		GREEN 125		GREEN 145		GREEN 160		GREEN 180	
Arbeitsbreite (cm)	115		125		145		160		180	
Schlegel G1	32		34		40		44		50	
Seitenverschiebung (mm)	750 + 400 430   720		750 + 500 430   820		805 + 645 485   965		885 + 715 565   1035		885 + 915 565   1235	
Gewicht min-max (Kg)	250	300	270	320	295	345	315	365	345	395



# PARK/P



25-60 CV



Ø 2-3 cm



	PARK/P 105		PARK/P 115		PARK/P 125		PARK/P 135		PARK/P 145		PARK/P 160		PARK/P 180	
Arbeitsbreite (cm)	105		115		125		135		145		160		180	
Schlegel L	10		10		12		12		14		14		16	
Messer VL	30		30		36		36		42		42		48	
Seitenverschiebung (mm)	590	460	590	560	690	560	775	575	775	675	875	715	875	915
	270	780	270	880	370	880	455	895	455	995	555	1045	555	1245
Gewicht min-max (Kg)	265	320	280	340	295	350	310	360	320	375	355	405	370	430



# MULCHGERÄTE

FÜR WEIN- UND OBSTGÄRTEN





# AF



30-60 CV



Ø 4-5 cm



**STRENX®**

	AF 135		AF 145		AF 160		AF 180	
Arbeitsbreite (cm)	135		145		160		180	
Schlegel P	12		14		14		16	
Messer YP	36		42		42		48	
Seitenverschiebung (mm)	715	635	715	735	715	885	715	1085
	345	1005	345	1105	345	1255	345	1455
Gewicht min-max (Kg)	375	460	400	480	425	500	460	525

# AF/L



Ø 5-6 cm



40-100 CV



**STRENX®**

	AF/L 105	AF/L 115	AF/L 125	AF/L 135	AF/L 145	AF/L 160	AF/L 180	AF/L 200	AF/L 220 NEW
Arbeitsbreite (cm)	105	115	125	135	145	160	180	200	220
Schlegel P	10	10	12	12	14	14	16	18	20
Messer YP	30	30	36	36	42	42	48	54	58
Seitenverschiebung (mm)	600   450 360   690	650   500 360   790	700   550 360   890	700   650 360   990	700   750 360   1090	700   900 360   1240	700   1100 360   1440	810   1190 440   1560	975   1225 600   1600
Seitenverschiebung (mittiger Anbau) (mm)	/	/	/	/	/	980   620 605   995	980   820 605   1195	1150   850 780   1220	1255   945 880   1320
Gewicht min-max (Kg)	455   535	465   545	475   560	485   575	505   600	550   645	595   690	645   740	695   790



# AF/LE *NEW*



60-100 CV



Ø 5-6 cm



**STRENX®**

	AF/LE 160		AF/LE 180		AF/LE 200		AF/LE 220	
Arbeitsbreite (cm)	160		180		200		220	
Schlegel P	14		16		18		20	
Messer YP	42		48		54		60	
Seitenverschiebung (mm)	940 0	660 1690	940 0	860 1790	940 0	1060 2130	940 0	1260 2330
Gewicht min-max (Kg)	540	595	585	640	630	685	675	730

# AF/REV



40-100 CV



Ø 5-6 cm



**STRENX®**

	AF/REV 105	AF/REV 115	AF/REV 125	AF/REV 135	AF/REV 145	AF/REV 160	AF/REV 180	AF/REV 200	AF/REV 220 <b>NEW</b>
<b>Arbeitsbreite (cm)</b>	105	115	125	135	145	160	180	200	220
<b>Schlegel P</b>	10	10	12	12	14	14	16	18	20
<b>Messer YP</b>	30	30	36	36	42	42	48	54	60
<b>Seitenverschiebung (mm)</b>	600   450 360   690	650   500 360   790	700   550 360   890	700   650 360   990	700   750 360   1090	700   900 360   1240	700   1100 360   1440	810   1190 440   1560	980   1220 605   1595
<b>Seitenverschiebung (mittiger Anbau) (mm)</b>	/	/	/	/	/	980   620 605   995	980   820 605   1195	1150   850 780   1220	1260   940 885   1315
<b>Gewicht min-max (Kg)</b>	455   535	465   545	475   560	485   575	505   600	550   645	595   690	645   740	695   790



# TFB/L *NEW*



60-110 CV



Ø 7 cm



**HARDOX®**

	TFB/L 170	TFB/L 190	TFB/L 210	TFB/L 230
Arbeitsbreite (cm)	170	190	210	230
Schlegel P	16	18	18	20
Messer YP	48	54	60	60
Seitenverschiebung (mm)	900 — 800 420 — 1280	900 — 1000 420 — 1480	1045 — 1055 520 — 1580	1045 — 1255 520 — 1780
Gewicht min-max (Kg)	590 — 750	630 — 790	670 — 830	710 — 870

# TFB/LR *NEW*



60-110 CV



Ø 7 cm

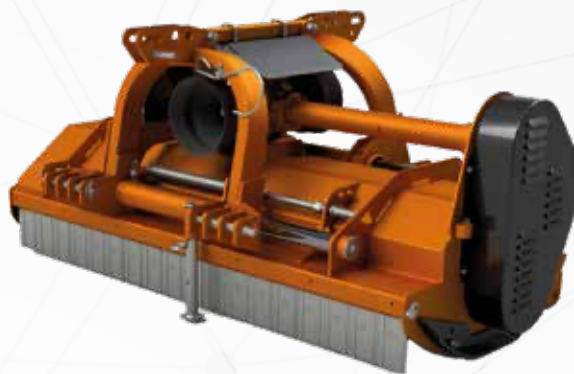

**HARDOX®**

	TFB/LR 170		TFB/LR 190		TFB/LR 210		TFB/LR 230	
Arbeitsbreite (cm)	170		190		210		230	
Schlegel P	16		18		18		20	
Messer YP	48		54		60		60	
Seitenverschiebung (mm)	810	890	810	1090	975	1125	975	1325
	440	1260	440	1460	600	1500	600	1700
Gewicht min-max (Kg)	660	740	700	780	740	820	780	860



# ZETA



60-110 CV



Ø 5-6 cm



**STRENX®**

	ZETA 150	ZETA 170	ZETA 190	ZETA 210	ZETA 230	ZETA 250
Arbeitsbreite (cm)	150	170	190	210	230	250
Schlegel P	8+8	8+8	10+10	10+10	12+12	12+12
Messer YP	24+24	24+24	30+30	30+30	36+36	36+36
Seitenverschiebung (mm)	940 + 560 560 + 940	1040 + 660 660 + 1040	1140 + 760 760 + 1140	1240 + 860 860 + 1240	1340 + 960 960 + 1340	1440 + 1060 1060 + 1440
Gewicht min-max (Kg)	690 800	740 850	790 900	840 950	890 1000	940 1050

# TFB/Y



60-110 CV



Ø 8 cm



**HARDOX®**

	TFB/Y 120		TFB/Y 140		TFB/Y 160		TFB/Y 180		TFB/Y 200		TFB/Y 220		TFB/Y 250	
Arbeitsbreite (cm)	120		140		160		180		200		220		250	
Schlegel A	12		12		14		16		18		20		22	
Messer YA	36		36		42		48		54		60		66	
Seitenverschiebung (mm)	685	515	875	525	875	725	875	925	875	1125	1040	1160	1040	1460
	315	885	355	1045	355	1245	355	1445	355	1645	520	1680	520	1980
Seitenverschiebung (mittiger Anbau) (mm)	/		/		1046	554	1046	754	1216	784	1326	874	1560	940
	/		/		524	1076	524	1276	694	1306	804	1396	1040	1460
Gewicht min-max (Kg)	560	720	610	770	660	840	700	890	740	940	790	990	890	1100



# TFB/YE *NEW*



70-110 CV



Ø 8 cm



**HARDOX®**

	TFB/YE 160		TFB/YE 180		TFB/YE 200		TFB/YE 220	
Arbeitsbreite (cm)	160		180		200		220	
Schlegel A	14		16		18		20	
Messer YA	42		48		54		60	
Seitenverschiebung (mm)	930	670	930	870	930	1070	930	725
	/	1730	/	1930	/	2130	/	2330
Gewicht min-max (Kg)	660	850	700	890	740	940	790	990

# TFB/C



60-110 CV



Ø 8 cm



**HARDOX®**

	TFB/C 140	TFB/C 160	TFB/C 180	TFB/C 200	TFB/C 220	TFB/C 250
Arbeitsbreite (cm)	140	160	180	200	220	250
Schlegel A	12	14	16	18	20	22
Messer YA	36	42	48	54	60	66
Seitenverschiebung (mm)	875   525 355   1045	875   725 355   1245	875   925 355   1455	875   1125 355   1645	1040   1160 520   1680	1040   1460 520   1980
Seitenverschiebung (mittiger Anbau) (mm)	/	1046   554 524   1076	1046   754 524   1276	1216   784 694   1306	1326   874 804   1396	1560   940 1040   1460
Gewicht min-max (Kg)	650   810	700   880	740   930	780   980	830   1030	930   1150



# TFB/REV



60-110 CV



Ø 8 cm



**HARDOX®**

	TFB/REV 140		TFB/REV 160		TFB/REV 180		TFB/REV 200		TFB/REV 220	
Arbeitsbreite (cm)	140		160		180		200		220	
Schlegel A	12		14		16		18		20	
Messer YA	36		42		48		54		60	
Seitenverschiebung (mm)	875   525 355   1045		875   725 355   1245		875   925 355   1455		875   1125 355   1645		1040   1160 520   1680	
Seitenverschiebung (mittiger Anbau) (mm)	/		1025   575 505   1095		1025   775 505   1295		1195   805 675   1325		1305   895 785   1415	
Gewicht min-max (Kg)	710	830	750	890	800	950	840	1000	890	1050

# TFB/M



70-150 CV



Ø 10-12 cm



**STRENX®**

	TFB/M 160 <i>NEW</i>		TFB/M 180		TFB/M 200		TFB/M 200 S		TFB/M 220		TFB/M 250		TFB/M 280		TFB/M 300									
Arbeitsbreite (cm)	160		180		200		200		220		250		280		300									
Schlegel M	14		16		18		18		20		22		26		28									
Seitenverschiebung (mm)	880 360	720 1240	956 434	844 1366	1046 524	954 1476	1046 524	954 1476	1046 524	1154 1646	1046 524	1454 1976	1046 524	1754 2276	1046 524	1954 2476								
Seitenverschiebung (mittiger Anbau) (mm)	/		/		/		/		1320 800		880 1400		1320 800		1180 1700		1616 1094		1184 1706		1616 1094		1384 1906	
Gewicht min-max (Kg)	825	940	875	995	925	1050	990	1125	1050	1195	1125	1280	1195	1365	1235	1415								



# TFB/ME



80-150 CV



Ø 10-12 cm

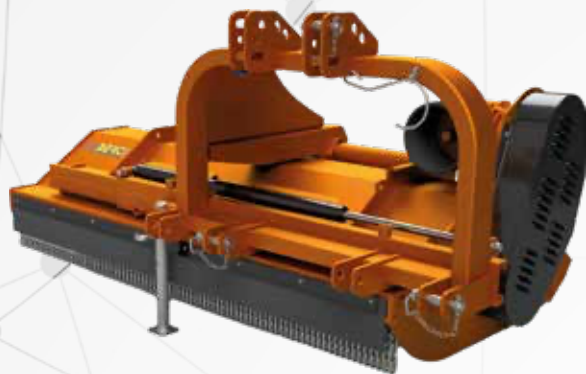

**STRENX®**

	TFB/ME 200		TFB/ME 220		TFB/ME 250	
<b>Arbeitsbreite (cm)</b>	200		220		250	
<b>Schlegel M</b>	18		20		22	
<b>Seitenverschiebung (mm) pos. 1</b>						
<b>Seitenverschiebung (mm) pos. 2</b>						
<b>Gewicht min-max (Kg)</b>	1110	1190	1190	1280	1280	1370

# SF/2 *NEW*



80-150 CV



Ø 10-12 cm

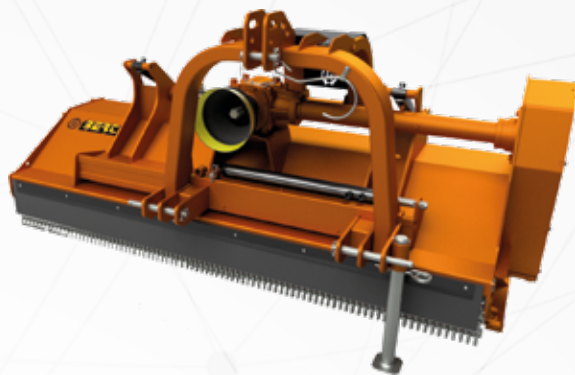

**HARDOX®**

	SF2 180	SF2 200	SF2 220	SF2 250
Arbeitsbreite (cm)	180	200	220	250
Schlegel M	16	18	20	22
Seitenverschiebung (mm)	520   1280 1040   760	730   1270 1250   750	800   1400 1320   880	980   1520 1500   1000
Gewicht min-max (Kg)	1050   1150	1125   1225	1195   1295	1280   1380



# SICHELMUCHER

FÜR WEIN- UND OBSTBAU



# EUROSTAR



40 -120 CV



	EUROSTAR 160	EUROSTAR 180	EUROSTAR 200	EUROSTAR 220	EUROSTAR 240
Arbeitsbreite (cm)	158	178	198	218	238
Gelenkige und belüftete Messer	4	4	4	4	4
Seitenverschiebung (mm)	790   790	890   890	990   990	1090   1090	1190   1190
Gewicht min (Kg)	390	420	470	490	520

# B-FLEX



40 - 120 CV



	B-FLEX 120-150		B-FLEX 140-195		B-FLEX 175-240		B-FLEX 190-260		B-FLEX 220-300	
Arbeitsbreite min-max (cm)	119	147	142	190	175	240	192	257	220	300
Gelenkige und belüftete Messer	4		4		4		4		4	
Seitenverschiebung (mm)	600 750   750		710 975   975		880 1200   1200		960 1300   1300		1100 1500   1500	
Gewicht min (Kg)	470		530		607		715		850	



# AV



50 -120 CV



	AV 180-230 Ø 65		AV 180-245 Ø 80		AV 200-250 Ø 65		AV 200-265 Ø 80		AV 235-290 Ø 65	
<b>Arbeitsbreite min-max (cm)</b>	176	230	192	243	200	252	200	266	235	287
<b>Gelenkige und belüftete Messer</b>	4		4		4		4		4	
<b>Seitenverschiebung (mm)</b>										
<b>Gewicht min (Kg)</b>	595		605		620		630		680	
	AV 235-300 Ø 80		AV 260-320 Ø 65		AV 260-335 Ø 80		AV 310-360 Ø 65		AV 310-375 Ø 80	
<b>Arbeitsbreite min-max (cm)</b>	240	299	264	317	264	331	312	366	316	376
<b>Gelenkige und belüftete Messer</b>	4		5		5		5		5	
<b>Seitenverschiebung (mm)</b>										
<b>Gewicht min (Kg)</b>	690		700		710		760		770	



# VARIANT



50 -120 CV



	VARIANT 160-260 Ø 60		VARIANT 160-260 Ø 70		VARIANT 180-280 Ø 60		VARIANT 180-300 Ø 70		VARIANT 180-320 Ø 80		VARIANT 200-300 Ø 60		VARIANT 200-320 Ø 70	
<b>Arbeitsbreite min-max (cm)</b>	158	266	158	284	178	280	178	298	178	315	198	300	198	318
<b>Gelenkige und belüftete Messer</b>	4+8		4+8		4+8		4+8		4+8		4+8		4+8	
<b>Seitenverschiebung (mm)</b>	800	800	800	800	900	900	900	900	900	900	1000	1000	1000	1000
	1330	1330	1420	1420	1400	1400	1490	1490	1570	1570	1500	1500	1590	1590
<b>Gewicht min (Kg)</b>	520	620	530	630	550	650	560	660	570	670	590	690	600	700
	VARIANT 200-340 Ø 80		VARIANT 200-360 Ø 90		VARIANT 220-320 Ø 60		VARIANT 220-340 Ø 70		VARIANT 220-360 Ø 80		VARIANT 220-380 Ø 90		VARIANT 240-400 Ø 90	
<b>Arbeitsbreite min-max (cm)</b>	198	343	198	352	218	321	218	341	218	356	226	375	238	399
<b>Gelenkige und belüftete Messer</b>	4+8		4+8		4+8		4+8		4+8		4+8		4+8	
<b>Seitenverschiebung (mm)</b>	1000	1000	1000	1000	1100	1100	1100	1100	1100	1100	1100	1100	1200	1200
	1720	1720	1760	1760	1610	1610	1710	1710	1780	1780	1880	1880	2000	2000
<b>Gewicht min (Kg)</b>	610	710	620	720	630	730	640	740	650	750	660	760	680	780



# ZWISCHENREIHEN- UND UNKRAUTMÄHER

A photograph of a vineyard with rows of grapevines. The vines are green and leafy, with some clusters of grapes visible. The ground between the rows is covered with grass and some weeds. The text 'ZWISCHENREIHEN- UND UNKRAUTMÄHER' is overlaid in white, bold, sans-serif font.



# ECOLOGY/AD *NEW*

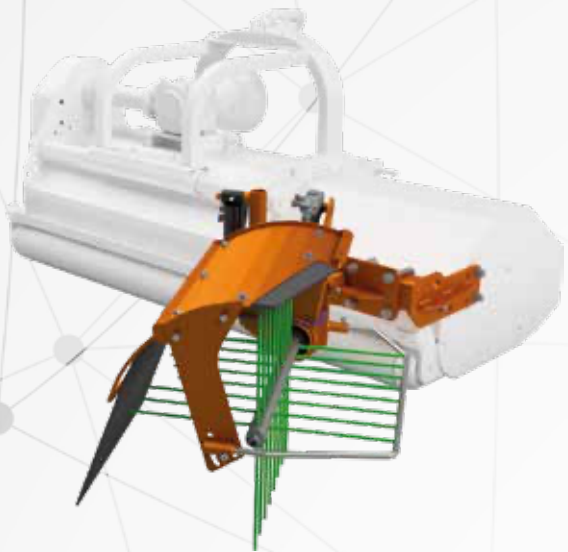

KOMPATIBILITÄT MIT MODELLEN DER SERIE

AF	135	145	160	180					
AF/L	105	115	125	135	145	160	180	200	220
AF/L mittiger Anbau	160	180	200	220					
TFB/L	170	190	210	230					
TFB/Y	140	160	180	200	220	250			
TFB/Y mittiger Anbau	160	180	200	220	250				
TFB/C	140	160	180	200	220	250			
TFB/C mittiger Anbau	160	180	200	220	250				

# ECOLOGY/AD2 *NEW*

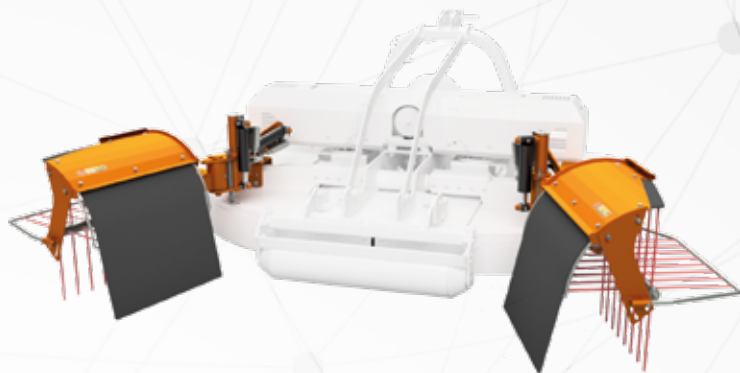

## KOMPATIBILITÄT MIT MODELLEN DER SERIE

ZETA	150*	170*	190*	210*	230*	250*
EUROSTAR	160	180	200	220	240	
B-FLEX	140-195	175-240	190-260	220-300		

\* begrenzte Verschiebung des Mulchers



# ECOLOGY *NEW*

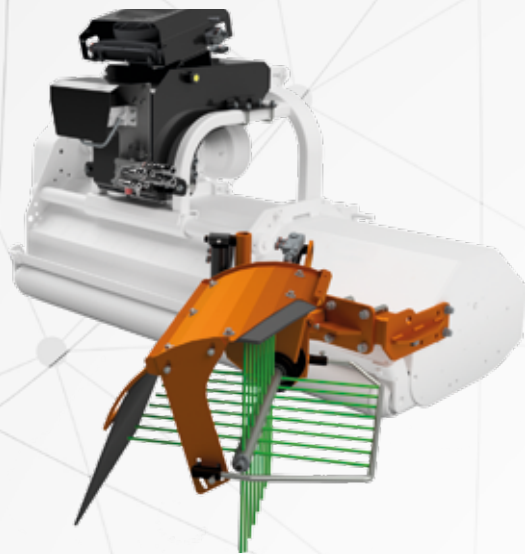

## KOMPATIBILITÄT MIT MODELLEN DER SERIE

AF/L	135	145	160	180	200	220
AF/L mittiger Anbau	160	180	200	220		
TFB/L	170	190	210	230		
TFB/Y	140	160	180	200	220	250
TFB/Y mittiger Anbau	160	180	200	220	250	
TFB/C	140	160	180	200	220	250
TFB/C mittiger Anbau	160	180	200	220	250	

# ECOSPRINT/M

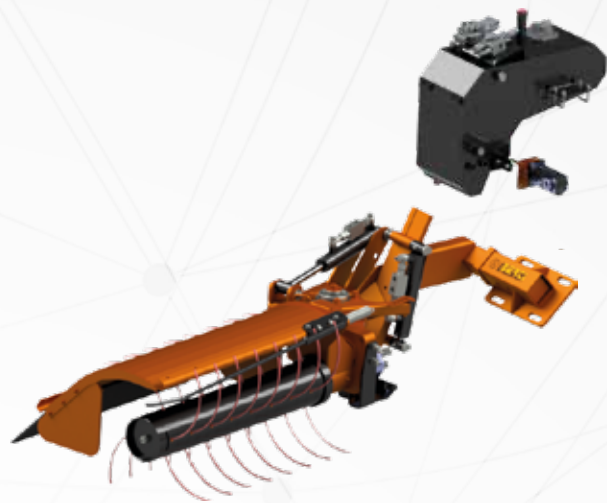

**HARDOX®**

## KOMPATIBILITÄT MIT MODELLEN DER SERIE

AF/L	135	145	160	180	200	220
AF/L mittiger Anbau	160	180	200	220		
TFB/L	170	190	210	230		
TFB/Y	140	160	180	200	220	250
TFB/Y mittiger Anbau	160	180	200	220	250	
TFB/C	140	160	180	200	220	250
TFB/C mittiger Anbau	160	180	200	220	250	



# RM/AD *NEW*

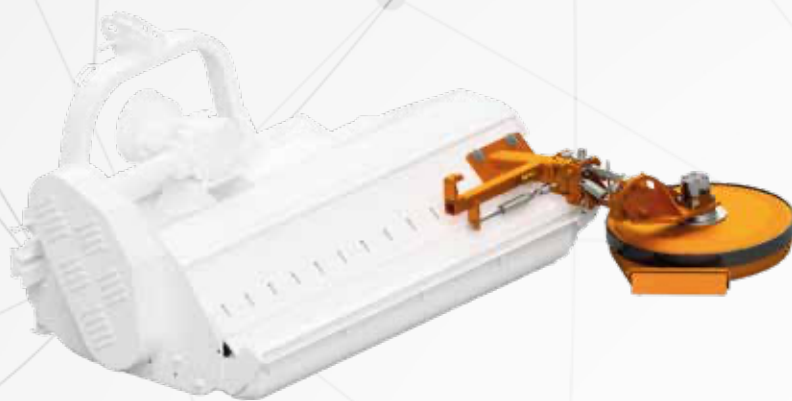

## KOMPATIBILITÄT MIT MODELLEN DER SERIE

AF	135	145	160	180					
AF/L	105	115	125	135	145	160	180	200	220
AF/L mittiger Anbau	160	180	200	220					
TFB/L	170	190	210	230					
TFB/Y	120	140	160	180	200	220	250		
TFB/Y mittiger Anbau	160	180	200	220	250				
TFB/C	140	160	180	200	220	250			
TFB/C mittiger Anbau	160	180	200	220	250				

# RM *NEW*

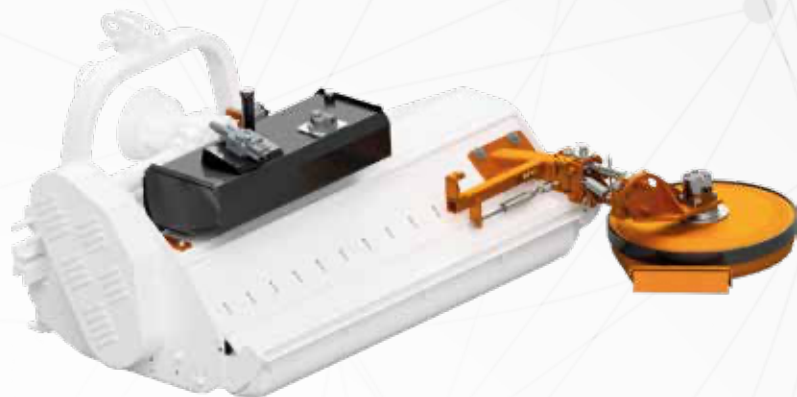

## KOMPATIBILITÄT MIT MODELLEN DER SERIE

AF/L mittiger Anbau	160	180	200	220		
TFB/L	170	190	210	230		
TFB/Y	140	160	180	200	220	250
TFB/Y mittiger Anbau	160	180	200	220	250	
TFB/C	140	160	180	200	220	250
TFB/C mittiger Anbau	160	180	200	220	250	



# RM/2 *NEW*

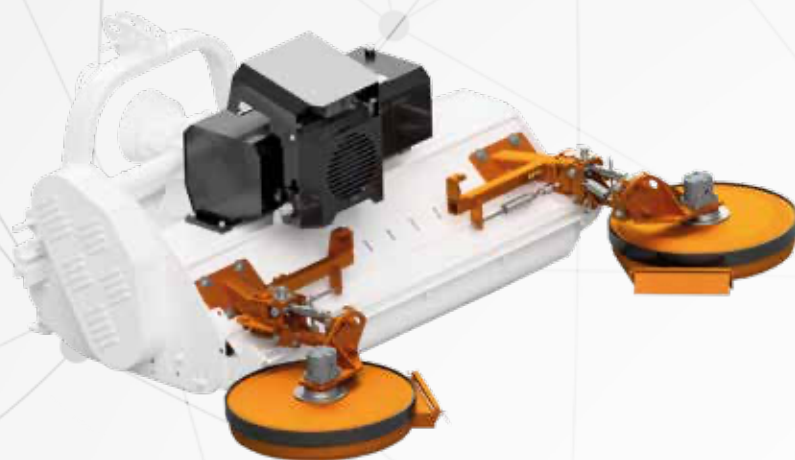

## SCHEIBE Ø 450 - KOMPATIBILITÄT MIT MODELLEN DER SERIE

AF/L	135	145	160	180	200	220
TFB/L	170	190	210	230		
TFB/Y - TFB/C	140	160	180	200	220	250

## SCHEIBE Ø 650 - KOMPATIBILITÄT MIT MODELLEN DER SERIE

AF/L	145	160	180	200	220	
TFB/L	170	190	210	230		
TFB/Y - TFB/C	140	160	180	200	220	250

## SCHEIBE Ø 800 - KOMPATIBILITÄT MIT MODELLEN DER SERIE

AF/L	180	200	220			
TFB/L	190	210	230			
TFB/Y - TFB/C	160	180	200	220	250	

# RI *NEW*



## KOMPATIBILITÄT MIT MODELLEN DER SERIE

AF/L	105	115	125	135	145	160	180	200	220
AF/L mittiger Anbau	160	180	200	220					
TFB/L	170	190	210	230					
TFB/Y	140	160	180	200	220	250			
TFB/Y mittiger Anbau	160	180	200	220	250				
TFB/C	140	160	180	200	220	250			
TFB/C mittiger Anbau	160	180	200	220	250				



# RI/2 *NEW*



## SCHEIBE Ø 450 - KOMPATIBILITÄT MIT MODELLEN DER SERIE

AF/L	145	160	180	200	220	
TFB/L	170	190	210	230		
TFB/Y - TFB/C	140	160	180	200	220	250

## SCHEIBE Ø 600 - KOMPATIBILITÄT MIT MODELLEN DER SERIE

AF/L	160	180	200	220		
TFB/L	170	190	210	230		
TFB/Y - TFB/C	160	180	200	220	250	

## SCHEIBE Ø 800 - KOMPATIBILITÄT MIT MODELLEN DER SERIE

AF/L	200	220				
TFB/L	190	210	230			
TFB/Y - TFB/C	180	200	220	250		

# SPEEDY

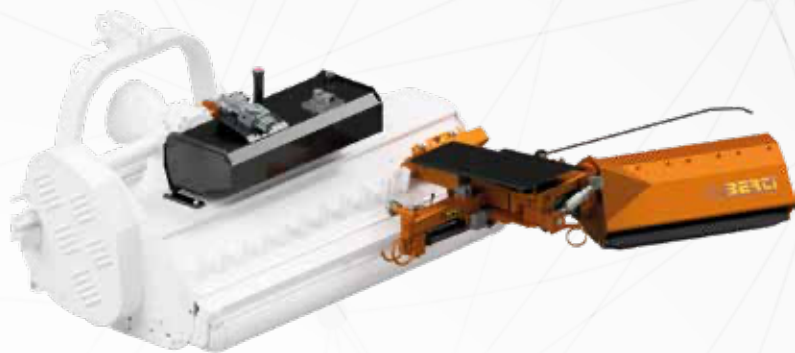

## KOMPATIBILITÄT MIT MODELLEN DER SERIE

TFB/Y - TFB/C	120	140	160	180	200	220	250
---------------	-----	-----	-----	-----	-----	-----	-----

# ECOSPRINT/EASY



30 -80 CV



**HARDOX®**

	ECOSPRINT/EASY 90/140		ECOSPRINT/EASY 140/240	
Arbeitsbreite (cm)	75		75	
Anzahl der Drähte	12		12	
Seitenverschiebung (mm)				
Gewicht min-max (Kg)	480	540	500	580

# ECOSPRINT



40 -100 CV



**HARDOX®**

	ECOSPRINT 90/140		ECOSPRINT 140/240	
Arbeitsbreite (cm)	75		75	
Anzahl der Drähte	16		16	
Seitenverschiebung (mm)				
Gewicht min-max (Kg)	480	540	500	580



# ECOSPRINT/D



50 - 100 CV



**HARDOX®**

	ECOSPRINT/D 180/230		ECOSPRINT/D 230/350		ECOSPRINT/D 230/400	
Arbeitsbreite (cm)	75x2		75x2		75x2	
Anzahl der Drähte	16+16		16+16		16+16	
Seitenverschiebung (mm)	900 1800	900 1800	1150 1750	1150 1750	1150 2000	1150 2000
Gewicht min-max (Kg)	740	780	760	800	780	820

# ECOROW



50 -100 CV



**HARDOX®**

	ECOROW (SV2)		ECOROW (SV3)		ECOROW (SV4)		ECOROW (SF2)		ECOROW (SF3)		ECOROW (SF4)	
Vordere Sterne	2		3		4		2		3		4	
Gewicht min-max (Kg)	300	390	310	400	320	410	390	480	400	490	410	500



# ECOROW/D



50 - 100 CV



**HARDOX®**

	ECOROW/D (DV2)		ECOROW/D (DV3)		ECOROW/D (DV4)		ECOROW/D (DF2)		ECOROW/D (DF3)		ECOROW/D (DF4)	
<b>Vordere Sterne</b>	2+2		3+3		4+4		2+2		3+3		4+4	
<b>Gewicht min-max (Kg)</b>	440	615	460	635	480	655	620	795	640	815	660	835

# RM AD/TL



40 -100 CV



**HARDOX®**

	RM AD/TL 90/140		RM AD/TL 140/240	
Scheibendurchmesser (cm)	65		65	
Anzahl der Messer	2		2	
Seitenverschiebung (mm)				
Gewicht min-max (Kg)	225	255	255	285



# SPEEDY/TL



50 - 100 CV



**HARDOX®**

	SPEEDY/TL 140/240	
Arbeitsbreite (cm)	60	
Schlegel	10	
Seitenverschiebung (mm)		
Gewicht min-max (Kg)	570	630





# SPEZIALMULCHER

MIT PICK-UP ROTOR FÜR BESCHNEIDUNGSRESTE (KEIN GRAS)



# PICKER®/L



60-100 CV



Ø 5 cm



	PICKER/L 85		PICKER/L 115		PICKER/L 135		PICKER/L 145		PICKER/L 160		PICKER/L 180 <i>NEW</i>	
<b>Arbeitsbreite (cm)</b>	85		115		135		145		160		180	
<b>Schlegel P</b>	12		14		16		18		22		24	
<b>Gewicht min-max (Kg)</b>	460	490	580	610	640	675	700	735	790	830	890	930

# PICKER®



60-120 CV



Schlegel Ø 8 cm - Forst-Hämmer Ø 12-15 cm



	PICKER 100		PICKER 120		PICKER 140		PICKER 150		PICKER 160		PICKER 180		PICKER 200	
Arbeitsbreite (cm)	100	950	120	1000	140	1100	150	1010	160	1070	180	1130	200	1190
Schlegel A	14		16		18		20		22		24		26	
Forst-Hämmer DF2	/		/		26		28		30		34		38	
Gewicht min-max (Kg)	800	950	850	1000	950	1100	1010	1180	1070	1250	1130	1310	1190	1370



# PICKER®/F



80-140 CV



Schlegel Ø 8 cm - Forst-Hämmer Ø 12-15 cm



	PICKER/F 160		PICKER/F 180	
Arbeitsbreite (cm)	160		180	
Schlegel A	22		24	
Forst-Hämmer DF2	30		34	
Gewicht min-max (Kg)	1270	1470	1350	1550

# PICKER®/FR *NEW*



80-160 CV



Schlegel Ø 8 cm - Forst-Hämmer Ø 12-15 cm



	PICKER/FR 150		PICKER/FR 160		PICKER/FR 180		PICKER/FR 200		PICKER/FR 220	
Arbeitsbreite (cm)	150		160		180		200		220	
Schlegel A	20		22		24		26		28	
Feste Zähne XF1	38		42		42		44		48	
Gewicht min-max (Kg)	960	1210	1020	1270	1150	1400	1280	1530	1410	1660



# PICKER®/C



60-140 CV

Schlegel Ø 8 cm - Forst-Hämmer Ø 12-15 cm



	PICKER/C 100	PICKER/C 120	PICKER/C 140	PICKER/C 150	PICKER/C 160	PICKER/C 180
Arbeitsbreite (cm)	100	120	140	150	160	180
Schlegel A	14	16	18	20	22	24
Forst-Hämmer DF2	/	/	26	28	30	34
Auswurfhöhe Kompakt (cm)	/	/	185	185	/	/
Auswurfhöhe Normal (cm)	230	230	230	/	230	230
Auswurfhöhe Super (cm)	305	305	305	/	305	305
M³ Behälter Kompakt	/	/	1,70	1,85	/	/
M³ Behälter Normal	1,50	1,80	2,10	/	2,40	2,70
M³ Behälter Super	1,90	2,30	2,70	/	3,10	3,50
Gewicht Behälter Kompakt (kg)	-	-	1460	1660	1570	1770
Gewicht Behälter Normal (kg)	1480	168	1560	176	1680	188
Gewicht Behälter Super (kg)	1590	1790	1720	1920	1840	2040
					-	-
					1790	199
					1860	2060
					1950	2150
					2030	2230

# PICKER®/R



70-140 CV



Schlegel Ø 8 cm - Forst-Hämmer Ø 12-15 cm



	PICKER/R 160		PICKER/R 180		PICKER/R 200 <i>NEW</i>	
Arbeitsbreite (cm)	160		180		200	
Schlegel A	22		24		26	
Forst-Hämmer DF2	30		34		38	
Gewicht min-max (Kg)	1190	1390	1240	1440	1290	1490



# PICKER®/KARGO



60-140 CV



Schlegel Ø 8 cm - Forst-Hämmer Ø 12-15 cm



	PICKER/KARGO 140		PICKER/KARGO 200	
Arbeitsbreite (cm)	140		200	
Schlegel A	18		22	
Forst-Hämmer DF2	26		38	
m³ Behälter	4,9		7,8	
Gewicht min-max (Kg)	2650	3000	3570	4000



# MULCHER



FÜR GRÜNFLÄCHEN, BRACHEN, STARKEN BEWUCHS



# EKR



30-100 CV



Ø 2-3 cm



	EKR 125	EKR 135	EKR 145	EKR 160	EKR 180	EKR 200
Arbeitsbreite (cm)	125	135	145	160	180	200
Schlegel L oder A	12	12	14	14	16	18
Messer YL oder YA	36	36	42	42	48	54
Seitenverschiebung (mm)	615   635	615   720	615   835	715   885	780   1020	950   1050
Gewicht min-max (Kg)	300   355	315   370	330   380	360   400	480   520	520   560

# EKR/M



60-100 CV



Ø 4-5 cm



	EKR/M 180		EKR/M 200		EKR/M 220 <i>NEW</i>	
Arbeitsbreite (cm)	180		200		220	
Schlegel L	16		18		20	
Messer YL	48		54		60	
Seitenverschiebung (mm)	615	635	615	735	1140	1060
Gewicht min-max (Kg)	460	525	510	575	560	625



# EKR/S



50-130 CV



Ø 4-5 cm



	EKR/S 180		EKR/S 200		EKR/S 220		EKR/S 250		EKR/S 280		EKR/S 300	
Arbeitsbreite (cm)	180		200		220		250		280		300	
Schlegel A	16		18		20		22		26		28	
Messer YA	48		54		60		66		78		84	
Seitenverschiebung (mm)	1040	760	1210	790	1320	880	1320	1180	1610	1190	1610	1390
	520	1280	690	1310	800	1400	800	1700	1040	1760	1040	1960
Gewicht min-max (Kg)	560	710	600	740	630	770	690	830	890	1030	920	1060

# BIMAX



70-130 CV



Ø 5-6 cm



**STRENX®**

	BIMAX 180		BIMAX 200		BIMAX 220		BIMAX 250		BIMAX 280		BIMAX 300	
Arbeitsbreite (cm)	180		200		220		250		280		300	
Schlegel A	16		18		20		22		26		28	
Messer YA	48		54		60		66		78		84	
Seitenverschiebung (mm)	1040	760	1210	790	1320	880	1320	1180	1610	1190	1610	1390
	520	1280	690	1310	800	1400	800	1700	1040	1760	1040	1960
Gewicht min-max (Kg)	560	710	600	740	630	770	690	830	890	1030	920	1060



# DUAL



70-160 CV



Ø 6-8 cm



**STRENX®**

	DUAL 200		DUAL 230		DUAL 250		DUAL 280		DUAL 300	
Arbeitsbreite (cm)	200		230		250		280		300	
Schlegel A	18		20		22		26		28	
Messer YA	54		60		66		78		84	
Seitenverschiebung (mm)	1040	960	1320	980	1320	1180	1610	1190	1610	1390
	520   1480		800   1500		800   1700		1090   1710		1090   1910	
Gewicht min-max (Kg)	875	975	940	1040	990	1090	1070	1170	1110	1210

# XPRO



100 - 250 CV



Ø 8-10 cm



**STRENX®**

	XPRO 230	XPRO 250	XPRO 280	XPRO 300
Arbeitsbreite (cm)	230	250	280	300
Schlegel M	20	22	26	28
Seitenverschiebung (mm)				
Gewicht min-max (Kg)	1355 1645	1415 1705	1520 1810	1560 1850



# XPRO/F



100-250 CV



Ø10-12 cm

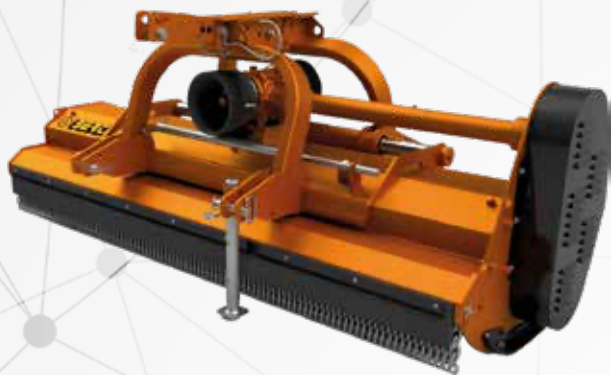

**STRENX®**

	XPRO/F 200	XPRO/F 230	XPRO/F 250	XPRO/F 280	XPRO/F 300
<b>Arbeitsbreite (cm)</b>	200	230	250	280	300
<b>Schlegel M</b>	18	20	22	26	28
<b>Seitenverschiebung (mm)</b>	1250 750 1320 1270	1320 980 800 1500	1500 1000 980 1520	1610 1190 1090 1710	1610 1390 1090 1910
<b>Gewicht min-max (Kg)</b>	1320 1600	1410 1700	1475 1765	1585 1875	1630 1920

# TBM



70 -110 CV



Ø 5-7 cm



**STRENX®**

	TBM 180		TBM 200		TBM 220		TBM 250		TBM 270	
<b>Arbeitsbreite (cm)</b>	200		230		250		280		300	
<b>Schlegel A</b>	16		18		20		22		24	
<b>Messer YA</b>	48		54		60		66		72	
<b>Seitenverschiebung (mm)</b>	875	925	1040	960	1040	1160	1040	1460	1040	1660
	355	1445	520	1480	520	1680	520	1980	520	2180
<b>Seitenverschiebung (mittiger Anbau) (mm)</b>	/		/		/		1465	1035	1587	1113
							945	1555	1065	1635
<b>Gewicht min-max (Kg)</b>	735	815	780	870	820	920	905	1025	935	1070



# TBM/S



80-150 CV



Ø 6-8 cm



**STRENX®**

	TBM/S 180		TBM/S 200		TBM/S 220		TBM/S 250		TBM/S 280		TBM/S 300	
<b>Arbeitsbreite (cm)</b>	180		200		220		250		280		300	
<b>Schlegel A oder M</b>	16		18		20		22		26		28	
<b>Messer YA</b>	48		54		60		66		78		84	
<b>Seitenverschiebung (mm)</b>	1050 530	750 1270	1050 530	950 1470	1050 530	1150 1670	1050 530	1450 1870	1050 530	1750 2270	1050 530	1950 2470
<b>Seitenverschiebung (mittiger Anbau) (mm)</b>	/		/		1325 800	875 1400	1520 1000	980 1500	1616 1094	1184 1706	1616 1094	1384 1906
<b>Gewicht min-max (Kg)</b>	860	970	900	1030	945	1090	1010	1170	1090	1260	1135	1310



# HOCHRAHMENMÄHER

FÜR MAISSTÄNGEL, STROH, FREILANDKULTUREN, STILLEGUNG





# TSB



60-140 CV



	TSB 160		TSB 180		TSB 200		TSB 220		TSB 230		TSB 250		TSB 280	
<b>Arbeitsbreite (cm)</b>	160		180		200		220		230		250		280	
<b>Messer 2YT</b>	40		44		48		52		56		60		68	
<b>Messer 3YT</b>	60		66		72		78		84		90		102	
<b>Schlepel T</b>	20		22		24		26		28		30		34	
<b>Seitenverschiebung (mm)</b>	780	820	780	1020	780	1220	1060	1140	805	1495	1060	1140	1350	1450
									1105	1195				
<b>Gewicht min-max (Kg)</b>	680	820	730	870	790	930	850	990	880	1020	1010	1150	1130	1270



# LAND



70 -150 CV



**STRENX®**

	LAND 160	LAND 180	LAND 200	LAND 230	LAND 250	LAND 280	LAND 300
Arbeitsbreite (cm)	160	180	200	230	250	280	300
Messer 2YT2	40	44	48	56	60	68	72
Messer 3YT2	60	66	72	84	90	102	108
Schlegel T2	20	22	24	28	30	34	36
Seitenverschiebung (mm)	780   820	780   1020	780   1220	805   1495 1105   1195	1065   1435	1350   1450	1350   1650
Gewicht min-max (Kg)	870   1035	920   1085	970   1125	1090   1230	1160   1300	1280   1415	1320   1445



# LAND/S



70-150 CV

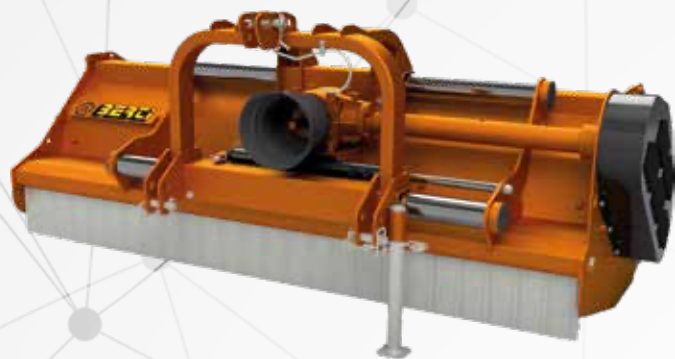

	LAND/S 160		LAND/S 180		LAND/S 200		LAND/S 230		LAND/S 250		LAND/S 280		LAND/S 300	
<b>Arbeitsbreite (cm)</b>	160		180		200		230		250		280		300	
<b>Messer 2YT2</b>	40		44		48		56		60		68		72	
<b>Messer 3YT2</b>	60		66		72		84		90		102		108	
<b>Schlegel T2</b>	20		22		24		28		30		34		36	
<b>Seitenverschiebung (mm)</b>	1042	558	1042	758	1042	958	1215	1085	1325	1175	1615	1185	1615	1385
	520	1080	520	1280	520	1480	694	1606	803	1697	1094	1706	1094	1906
<b>Gewicht min-max (Kg)</b>	950	1115	1000	1165	1050	1205	1170	1310	1240	1380	1360	1495	1400	1525

# KING/DT



90 -180 CV

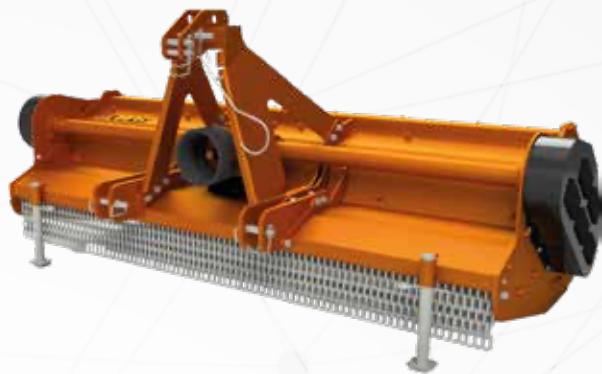

	KING/DT 200	KING/DT 270	KING/DT 320
Arbeitsbreite (cm)	200	270	320
Messer 2YT2	48	64	80
Messer 3YT2	72	96	120
Schlegel T2	24	32	40
Seitenverschiebung (mm)	1000   1000	1350   1350	1600   1600
Gewicht min-max (Kg)	1260   1590	1500   1830	1690   2090



# LAND/P



120-300 CV



**STRENX®**

	LAND/P 400	LAND/P 500	LAND/P 600
Arbeitsbreite (cm)	400	500	600
Messer 2YT2	96	120	144
Messer 3YT2	144	180	216
Schlegel T2	48	60	72
Seitenverschiebung (mm)	2000   2000	2500   2500	3000   3000
Gewicht min-max (Kg)	2530   3050	3090   3570	3600   4070

# LAND/P SERIE BioG **NEW**



250 - 380 CV



**STRENX®**

## LAND/P SERIE BIOG 600

Arbeitsbreite (cm)	600	
Schlegel T2	72	
Seitenverschiebung (mm)	3000 ←	→ 3000
Gewicht min-max (Kg)	4480	4520



# BÖSCHUNGSMULCHER

The background image shows a wide, green field with tall grasses in the foreground. In the distance, there is a line of trees under a cloudy sky. The overall scene is a natural, rural landscape.

FÜR BÖSCHUNGEN UND GRÄBEN



# TA/K



30-50 CV



Ø 2 cm



	TA/K 115		TA/K 125		TA/K 145	
Arbeitsbreite (cm)	115		125		145	
Schlegel G	32		34		40	
Gewicht min-max (Kg)	300	345	310	355	330	375

# TA/LI



40-70 CV



Ø 3-4 cm



	TA/LI 135		TA/LI 145		TA/LI 160	
Arbeitsbreite (cm)	135		145		160	
Schlegel L	12		14		14	
Messer YL	36		42		42	
Gewicht min-max (Kg)	435	515	445	525	460	540

# TA/L



40-70 CV



Ø 3-4 cm



	TA/L 115		TA/L 135		TA/L 145	
Arbeitsbreite (cm)	115		135		145	
Schlegel L	10		12		14	
Messer YL	30		36		42	
Gewicht min-max (Kg)	395	485	425	505	450	530

# TA/MI



50-100 CV



Ø 4-5 cm



**STRENX®**

	TA/MI 145		TA/MI 160		TA/MI 180		TA/MI 200	
Arbeitsbreite (cm)	145		160		180		200	
Schlegel P	14		14		16		18	
Messer YP	42		42		48		54	
Gewicht min-max (Kg)	585	695	620	730	660	770	685	795



# TA/M



50-100 CV



Ø 4-5 cm



**STRENX®**

	TA/M 145		TA/M 160		TA/M 180		TA/M 200	
Arbeitsbreite (cm)	145		160		180		200	
Schlegel P	14		14		16		18	
Messer YP	42		42		48		54	
Gewicht min-max (Kg)	610	720	640	750	680	790	720	830

# TA



80 - 120 CV



Ø 7-8 cm



**STRENX®**

	TA 160		TA 180		TA 200		TA 220		TA 250	
Arbeitsbreite (cm)	160		180		200		220		250	
Schlegel A	14		16		18		20		22	
Messer YA	42		48		54		60		66	
Gewicht min-max (Kg)	780	885	815	925	855	975	900	1030	980	1110



# TA/S



80-120 CV



Ø 7-8 cm



**STRENX®**

	TA/S 160		TA/S 180		TA/S 200		TA/S 220	
Arbeitsbreite (cm)	160		180		200		220	
Schlegel A	14		16		18		20	
Messer YA	42		48		54		60	
Gewicht min-max (Kg)	810	915	845	955	885	1005	925	1055

# TA/P



80-200 CV



Ø 10 cm



**STRENX®**

	TA/P 160		TA/P 180		TA/P 200		TA/P 220		TA/P 250	
Arbeitsbreite (cm)	160	180	200	220	250					
Schlegel A	14	16	18	20	22					
Messer YA	42	48	54	60	66					
Gewicht min-max (Kg)	940	1095	990	1145	1040	1195	1090	1245	1155	1310



# TA/PS



90-200 CV



Ø 10 cm



**STRENX®**

	TA/PS 180		TA/PS 200		TA/PS 220		TA/PS 250	
Arbeitsbreite (cm)	180		200		220		250	
Schlegel A	16		18		20		22	
Messer YA	48		54		60		66	
Gewicht min-max (Kg)	1015	1185	1060	1230	1110	1280	1175	1345

# TA/MF *NEW*



150-250 CV



Ø 4-5 cm



**STRENX®**

	TA/MF 160		TA/MF 180		TA/MF 200		TA/MF 220	
Arbeitsbreite (cm)	160		180		200		220	
Schlegel A	14		16		18		20	
Messer YA	42		48		54		60	
Gewicht min-max (Kg)	1050	1420	1100	1470	1150	1520	1200	1750



# FORST-MULCHER

FÜR BRACHLANDPFLEGE, ÄSTEN UND STÄMME



# KX *NEW*



60-110 CV



Ø 12-15 cm



**HARDOX®**



Forstrotor Smooth Cut

	KX 150		KX 170		KX 190	
Arbeitsbreite (cm)	150		170		190	
Feste Zähne XF2	48		54		60	
Seitenverschiebung (mm)	750	750	850	850	950	950
Gewicht min-max (Kg)	690	810	770	890	850	970

# ECF/MD



90-160 CV



Ø 15-18 cm

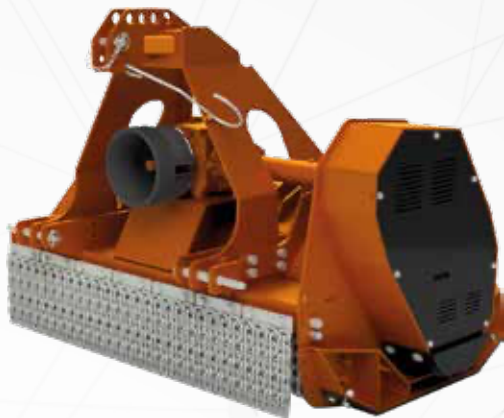

**STRENX® HARDOX®**

	ECF/MD 160		ECF/MD 180		ECF/MD 200		ECF/MD 220	
Arbeitsbreite (cm)	160		180		200		220	
Forst-Hämmer DF	28		32		36		40	
Forst-Hämmer MF	28		32		36		40	
Schlegel MWF	28		32		36		40	
Seitenverschiebung (mm)	680	920	880	920	880	1120	1080	1120
Gewicht min-max (Kg)	1150	1355	1240	1445	1320	1535	1405	1620



# EFX/MD



90-160 CV



Ø 20 cm



**STRENX®** **HARDOX®**



Forstrotor Smooth Cut

	EFX/MD 160		EFX/MD 180		EFX/MD 200		EFX/MD 220	
Arbeitsbreite (cm)	160		180		200		220	
Feste Zähne XFI	42		42		44		48	
Seitenverschiebung (mm)	680	920	880	920	880	1120	1080	1120
Gewicht min-max (Kg)	1165	1370	1230	1435	1290	1505	1370	1590

# ECF



110-200 CV



Ø 25 cm



**STRENX® HARDOX®**

	ECF 180		ECF 200		ECF 220	
Arbeitsbreite (cm)	180		200		220	
Forst-Hämmer DF	32		36		39	
Forst-Hämmer MF	32		36		39	
Schlegel MWF	32		36		39	
Seitenverschiebung (mm)	900	900	1000	1000	1100	1100
Gewicht min-max (Kg)	1930	2400	2050	2500	2170	2650



# EFX



110-200 CV



Ø 30 cm



**STRENX® HARDOX®**



Forstrotor Smooth Cut

	EFX 200	EFX 220
Arbeitsbreite (cm)	200	220
Feste Zähne XF2 - XP - XWP	44	48
Seitenverschiebung (mm)	1000   1000	1100   1100
Gewicht min-max (Kg)	1940   2500	2040   2650

# ECF/DT



110-250 CV



Ø 30 cm



**STRENX® HARDOX®**

	ECF/DT 200	ECF/DT 220	ECF/DT 250
Arbeitsbreite (cm)	200	220	250
Forst-Hämmer DF	36	39	45
Forst-Hämmer MF	36	39	45
Schlegel MWF	36	39	45
Seitenverschiebung (mm)	1000   1000	1100   1100	1250   1250
Gewicht min-max (Kg)	2100   2450	2250   2620	2500   2880



# EFX/DT



120-250 CV



Ø 40 cm

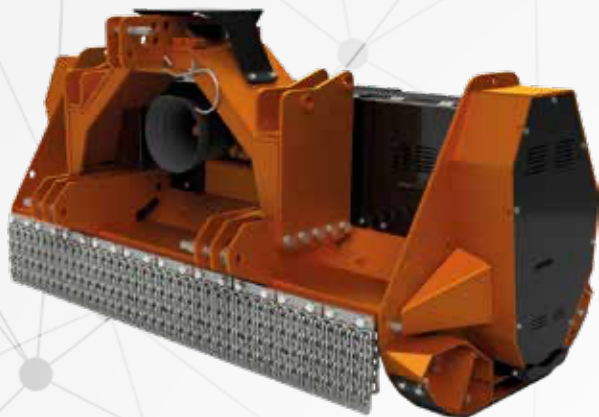

**STRENX® HARDOX®**



Forstrotor Smooth Cut

	EFX/DT 200	EFX/DT 220	EFX/DT 250
Arbeitsbreite (cm)	200	220	250
Feste Zähne XF - XP - XWP	44	48	54
Seitenverschiebung (mm)	1000   1000	1100   1100	1250   1250
Gewicht min-max (Kg)	2000   2350	2140   2510	2380   2760

# FOREST PRO



250-400 CV



Ø 50 cm



**STRENX® HARDOX®**



Forstrotor Smooth Cut

	FOREST PRO 250	
Arbeitsbreite (cm)	250	
Feste Zähne XP - XWP	54	
Seitenverschiebung (mm)	1250 ←	→ 1250
Gewicht min-max (Kg)	3500	5000



# KREISELKETTENMÄHER





# TC/M



40 - 80 CV



Ø 3-5 cm



	TC/M 150
Arbeitsbreite (cm)	150
Ketten G80	2
Gewicht (Kg)	395

# TC/P



80 -110 CV



Ø 3-5 cm



**HARDOX®**



	TC/P 180
Arbeitsbreite (cm)	180
Ketten G80	2
Gewicht (Kg)	670



# TC/PH



90 -110 CV



Ø 3-5 cm



**HARDOX®**



	TC/PH 180
Arbeitsbreite (cm)	180
Ketten 680	2
Gewicht (Kg)	690



# HYDRAULISCHE AUSLEGERSMÄHER

A scenic view of a winding asphalt road on a rocky hillside. The road curves to the right, bordered by a metal guardrail. The background shows a clear blue sky and distant hills. The text 'HYDRAULISCHE AUSLEGERSMÄHER' is overlaid in large white letters.



# FB/X



20-30 CV



Ø 2 cm



	FB/X
Arbeitsbreite (cm)	150
Drehung des Kopfes	360°
Tankinhalt (lt)	40
Mindestgewicht Traktor (Kg)	700
Gewicht (Kg)	280

# FB/G 250-250S



20-30 CV



Ø 2 cm



	FB/G 250	FB/G 250 S
Arbeitsbreite (cm)	60	60
Drehung des Kopfes	190°	190°
Tankinhalt (lt)	70	70
Messer Y	24	24
Mindestgewicht Traktor (Kg)	900	900
Gewicht (Kg)	315	350



# FB/G 300-300S-380-380S



40-60 CV



Ø 2 cm



	FB/G 300	FB/G 300 S	FB/G 380	FB/G 380 S
Arbeitsbreite (cm)	80	80	80	80
Drehung des Kopfes	190°	190°	190°	190°
Tankinhalt (lt)	95	95	95	95
Messer	32	32	32	32
Mindestgewicht Traktor (Kg)	1300	1300	1400	1400
Gewicht (Kg)	480	510	490	520

# FB/PG 320



40-60 CV



Ø 3 cm



**STRENX®**

	FB/PG 320
Arbeitsbreite (cm)	80
Drehung des Kopfes	190°
Tankinhalt (lt)	95
Messer	32
Mindestgewicht Traktor (Kg)	1500
Gewicht (Kg)	550



# FB/PG 440-480



70-90 CV



Ø 4 cm



**STRENX®**

	FB/PG 440	FB/PG 480
Arbeitsbreite (cm)	100	100
Drehung des Kopfes	190°	190°
Tankinhalt (lt)	120	120
Messer	40	40
Mindestgewicht Traktor (Kg)	2600	3200
Gewicht (Kg)	765	785

# FB/P 400S-480-560



70-100 CV



Ø 4 cm



**STRENX®**

	FB/P 400S	FB/P 480	FB/P 560
Arbeitsbreite (cm)	100	100	100
Drehung des Kopfes	190°	190°	190°
Tankinhalt (lt)	120	120	120
Messer	40	40	40
Mindestgewicht Traktor (Kg)	2400	2600	3000
Gewicht (Kg)	700	740	760



# FB/ARC STX 380



60-90 CV



Ø 3 cm



**STRENX®**

## FB/ARC 380 STX

Arbeitsbreite (cm)	80
Drehung des Kopfes	190°
Min Breite des Arms (cm)	90
Max Höhe des Arms (cm)	270
Tankinhalt (lt)	95
Messer	32
Mindestgewicht Traktor (Kg)	2200
Gewicht (Kg)	620

# FB/ARC STX 430-600



80-100 CV



Ø 2 cm



**STRENX®**

	FB/ARC 430 STX	FB/ARC 600 STX
Arbeitsbreite (cm)	100	100
Drehung des Kopfes	190°	190°
Min Breite des Arms (cm)	120	130
Max Höhe des Arms (cm)	300	320
Tankinhalt (lt)	125	125
Messer	40	40
Mindestgewicht Traktor (Kg)	3000	3500
Gewicht (Kg)	920	960



# FB/P 430



70-100 CV



Ø 4 cm



**STRENX®**

	FB/P 430
Arbeitsbreite (cm)	100
Drehung des Kopfes	245°
Tankinhalt (lt)	125
Messer	40
Mindestgewicht Traktor (Kg)	3000
Gewicht (Kg)	880

# FB/P 500-580



80-120 CV



Ø 5 cm



**STRENX®**

	FB/P 500	FB/P 580
Arbeitsbreite (cm)	100	100
Drehung des Kopfes	245°	245°
Tankinhalt (lt)	140	140
Messer	40	40
Mindestgewicht Traktor (Kg)	3500	3800
Gewicht (Kg)	960	1080



# FB/P 600



90-140 CV



Ø 5 cm



**STRENX®**

	FB/P 600
Arbeitsbreite (cm)	120
Drehung des Kopfes	245°
Tankinhalt (lt)	225
Messer	48
Mindestgewicht Traktor (Kg)	4200
Gewicht (Kg)	1370

# FB/T 660-730



100-150 CV



Ø 5 cm



**STRENX®**

	FB/T 660	FB/T 730
Arbeitsbreite (cm)	120	120
Drehung des Kopfes	245°	245°
Tankinhalt (lt)	225	225
Messer	48	48
Mindestgewicht Traktor (Kg)	4500	5000
Gewicht (Kg)	1420	1470



# FB/P SA 500-600



90-150 CV



Ø 5 cm



**STRENX®**

	FB/P 500 SA	FB/P 600 SA
Arbeitsbreite (cm)	100	120
Drehung des Kopfes	245°	245°
Tankinhalt (lt)	140	225
Messer	40	48
Mindestgewicht Traktor (Kg)	3500	4800
Gewicht (Kg)	1020	1430

# FB/P A.H.G. 500-600



100-150 CV



Ø 5 cm



**STRENX®**

	FB/P 500 AHG	FB/P 600 AHG
Arbeitsbreite (cm)	100	120
Drehung des Kopfes	245°	245°
Tankinhalt (lt)	140	225
Messer Y	40	48
Mindestgewicht Traktor (Kg)	4000	5000
Gewicht (Kg)	1100	1540



A close-up photograph of dark brown, textured soil, likely from a construction site. The soil is composed of small, irregular clumps and particles, creating a rough, granular surface. The lighting is somewhat uneven, with brighter areas in the upper right and darker, more shadowed areas in the lower left. Overlaid on this background is the text 'STEINVERGRÄBER' and 'UMKEHRFRÄSE' in a bold, white, sans-serif font. The text is centered horizontally and occupies the upper two-thirds of the image.

# STEINVERGRÄBER UMKEHRFRÄSE



# IS/K



15-28 CV



	IS/K 90	IS/K 100	IS/K 120
Arbeitsbreite (cm)	90	100	120
Arbeitstiefe (cm)	12	12	12
Anzahl der Werkzeuge	10+10	12+12	14+14
Gewicht der Kufenversion (kg)	180	200	215
Gewicht der Netzversion (Ø 30 cm) kg	220	240	260

# IS/L



20-45 CV



	IS/L 100	IS/L 120	IS/L 135
Arbeitsbreite (cm)	101	117	133
Arbeitstiefe (cm)	14	14	14
Anzahl der Werkzeuge	12+12	14+14	16+16
Gewicht der Kufenversion (kg)	315	335	355
Gewicht der Netzversion (Ø 42 cm) kg	370	405	435
Gewicht der Stabversion (Ø 43 cm) kg	345	375	410
Gewicht der Packerversion (Ø 48 cm) kg	325	415	445



# IS/M



30-75 CV



	IS/M 120	IS/M 140	IS/M 165	IS/M 185	IS/M 205
Arbeitsbreite (cm)	120	140	165	185	205
Arbeitstiefe (cm)	15	15	15	15	15
Anzahl der Werkzeuge	15+15	18+18	21+21	24+24	27+27
Gewicht der Kufenversion (kg)	465	505	550	590	630
Gewicht der Netzversion (Ø 42 cm) kg	545	590	635	680	720
Gewicht der Stabversion (Ø 43 cm) kg	/	570	620	665	700
Gewicht der Packerversion (Ø 48 cm) kg	/	685	735	775	860

# IS/G *NEW*



50-120 CV



	IS/G 165	IS/G 185	IS/G 205	IS/G 230	IS/G 250
Arbeitsbreite (cm)	165	185	205	230	250
Arbeitstiefe (cm)	15	15	15	15	15
Anzahl der Werkzeuge	21+21	24+24	27+27	30+30	33+33
Gewicht der Netzversion (Ø 41 cm) kg	795	850	900	950	1010
Gewicht der Stabversion (Ø 43 cm) kg	675	720	745	797	847
Gewicht der Packerversion (Ø 48 cm) kg	775	840	885	957	1027



# IS/H



100-170 CV



	IS/H 250	IS/H 280	IS/H 300
Arbeitsbreite (cm)	249	275	301
Arbeitstiefe (cm)	23	23	23
Anzahl der Werkzeuge	27+27	30+30	33+33
Gewicht der Stabversion (Ø 56 cm) kg	1380	1505	1635
Gewicht der Packerversion (Ø 57 cm) kg	1540	1680	1825

# IS/P



130-220 CV



	IS/P 250	IS/P 300	IS/P 350	IS/P 400
Arbeitsbreite (cm)	247	299	351	403
Arbeitstiefe (cm)	26	26	26	26
Anzahl der Werkzeuge	27+27	33+33	39+39	45+45
Gewicht der Netzversion (Ø 56 cm) kg	1900	2070	2320	2600
Gewicht der Stabversion (Ø 56 cm) kg	1800	2070	2285	2500
Gewicht der Packerversion (Ø 57 cm) kg	2000	2270	2520	2800



# BODENFRÄSE

The image shows a close-up, low-angle view of a field of dark, rich brown soil that has been recently tilled. The soil is uneven and clumpy, with many small clods and some larger pieces of dried plant matter, likely corn stalks, scattered throughout. The background is a soft-focus landscape of more tilled fields under a clear, light blue sky. The overall scene conveys a sense of agricultural activity and soil preparation.



# SOLE



15-25 CV



	SOLE 90	SOLE 100	SOLE 120
Arbeitsbreite (cm)	85	100	120
Arbeitstiefe (cm)	12	12	12
Anzahl der Werkzeuge	10+10	12+12	14+14
Seitenverschiebung (mm)	580   270   580	630   370   730	730   470   930
Gewicht (kg)	105	115	125

# MERCURIO



20-40 CV



	MERCURIO 100	MERCURIO 120	MERCURIO 135	MERCURIO 150	MERCURIO 165
Arbeitsbreite (cm)	100	120	135	150	165
Arbeitstiefe (cm)	15	15	15	15	15
Anzahl der Werkzeuge	18+18	21+21	24+24	27+27	30+30
Seitenverschiebung (mm)	512   488 280   720	707   493 280   920	707   643 280   1070	817   683 280   1220	817   833 280   1370
Gewicht (kg)	275	290	310	325	345



# MARTE



30-75 CV



	MARTE 140	MARTE 165	MARTE 185	MARTE 205
Arbeitsbreite (cm)	140	165	185	205
Arbeitstiefe (cm)	15	15	15	15
Anzahl der Werkzeuge	18+18	21+21	24+24	27+27
Seitenverschiebung (mm)	670   740 320   1090	810   820 410   1240	920   930 520   1330	1030   1040 630   1440
Gewicht (kg)	465	495	525	560

# VENERE



20-35 CV



	VENERE 90	VENERE 100	VENERE 120	VENERE 135
Arbeitsbreite (cm)	85	101	117	133
Arbeitstiefe (cm)	12	12	12	12
Anzahl der Werkzeuge	10+10	12+12	14+14	16+16
Gewicht (kg)	125	135	150	160



# TERRA



15-40 CV



	TERRA 90	TERRA 100	TERRA 120	TERRA 135	TERRA 150	TERRA 165	TERRA 180
Arbeitsbreite (cm)	87	100	120	135	150	165	180
Arbeitstiefe (cm)	14	14	14	14	14	14	14
Anzahl der Werkzeuge	10+10	12+12	14+14	16+16	18+18	20+20	22+22
Gewicht (kg)	195	210	225	240	250	265	285



# NETTUNO



25-50 CV



	NETTUNO 150	NETTUNO 165	NETTUNO 180
Arbeitsbreite (cm)	150	180	195
Arbeitstiefe (cm)	15	15	15
Anzahl der Werkzeuge	27+27	30+30	33+33
Gewicht der Kufenversion (kg)	295	310	325
Gewicht der Stabversion (Ø 32 cm) kg	358	382	405
Gewicht der Zinkenversion (Ø 45 cm) kg	363	386	408
Gewicht der Netzversion (Ø 41 cm) kg	405	435	460
Gewicht der Packversion (Ø 37 cm) kg	405	435	465



# URANO



30-75 CV



	URANO 100	URANO 120	URANO 140	URANO 165	URANO 185	URANO 205	URANO 230
Arbeitsbreite (cm)	100	120	140	165	185	205	230
Arbeitstiefe (cm)	15	15	15	15	15	15	15
Anzahl der Werkzeuge	12+12	15+15	18+18	21+21	24+24	27+27	30+30
Gewicht der Kufenversion (kg)	315	350	385	415	440	485	510
Gewicht der Stabversion (Ø 32 cm) kg	375	400	435	470	505	545	580
Gewicht der Zinkenversion (Ø 48 cm) kg	365	405	440	475	505	545	580
Gewicht der Netzversion (Ø 42 cm) kg	398	433	483	518	553	598	/
Gewicht der Packerversion (Ø 37 cm) kg	395	435	475	515	565	620	670

# SATURNO



30-75 CV



	SATURNO 120	SATURNO 140	SATURNO 165	SATURNO 185	SATURNO 205	SATURNO 230
Arbeitsbreite (cm)	120	140	165	185	205	230
Arbeitstiefe (cm)	15	15	15	15	15	15
Anzahl der Werkzeuge	15+15	18+18	21+21	24+24	27+27	30+30
Gewicht der Kufenversion (kg)	355	390	415	440	490	510
Gewicht der Stabversion (Ø 32 cm) kg	400	445	475	510	550	590
Gewicht der Zinkenversion (Ø 45 cm) kg	410	455	495	520	580	615
Gewicht der Netzversion (Ø 42 cm) kg	438	488	523	558	603	/
Gewicht der Packerversion (Ø 37 cm) kg	440	480	520	565	625	675



# GIOVE



50-130 CV



	GIOVE 155	GIOVE 165	GIOVE 185	GIOVE 205	GIOVE 230	GIOVE 250	GIOVE 280	GIOVE 300
Arbeitsbreite (cm)	154	164	186	208	230	252	273	295
Arbeitstiefe (cm)	20	20	20	20	20	20	20	20
Anzahl der Werkzeuge	18+18	21+21	24+24	27+27	30+30	33+33	36+36	39+39
Gewicht der Kufenversion (kg)	595	620	650	680	730	765	800	840
Gewicht der Stabversion (Ø 43 cm) kg	/	720	760	800	860	905	990	1050
Gewicht der Zinkenversion (Ø 48 cm) kg	/	730	775	820	885	935	985	1035
Gewicht der Spiralversion (Ø 47 cm) kg	/	770	810	855	925	975	1030	1095
Gewicht der Netzversion (Ø 41 cm) kg	/	860	910	975	1033	1088	/	/
Gewicht der Packerverversion (Ø 48 cm) kg	/	840	900	960	1040	1105	1170	1235

# POLARIS



100-170 CV



	POLARIS 250	POLARIS 280	POLARIS 300
Arbeitsbreite (cm)	249	275	301
Arbeitstiefe (cm)	23	23	23
Anzahl der Werkzeuge	27+27	30+30	33+33
Gewicht der Kufenversion (kg)	1120	1225	1335
Gewicht der Stabversion (Ø 56 cm) kg	1360	1485	1615
Gewicht der Zinkenversion (Ø 55 cm) kg	1400	1525	1655
Gewicht der Packversion (Ø 57 cm) kg	1505	1645	1790



# GIOVE BIO



60-130 CV



	GIOVE BIO 155	GIOVE BIO 165	GIOVE BIO 185	GIOVE BIO 205	GIOVE BIO 230	GIOVE BIO 250	GIOVE BIO 280	GIOVE BIO 300
Arbeitsbreite (cm)	155	165	185	205	230	250	280	300
Arbeitstiefe (cm)	20	20	20	20	20	20	20	20
Anzahl der Werkzeuge	18 + 18	21+21	24+24	27+27	30+30	33+33	36+36	39+39
Gewicht der Kufenversion (kg)	740	780	820	860	900	930	970	1010

# POLARIS BIO



100-170 CV



	POLARIS BIO 250	POLARIS BIO 280	POLARIS BIO 300
Arbeitsbreite (cm)	249	275	301
Arbeitstiefe (cm)	23	23	23
Anzahl der Werkzeuge	27+27	30+30	33+33
Gewicht der Kufenversion (kg)	1365	1415	1460



# LUNA



130-250 CV



	LUNA 250	LUNA 300	LUNA 350	LUNA 400
Arbeitsbreite (cm)	247	299	351	403
Arbeitstiefe (cm)	26	26	26	26
Anzahl der Werkzeuge	27+27	33+33	39+39	45+45
Gewicht der Kufenversion (kg)	1570	1610	1655	1700
Gewicht der Stabversion (Ø 56 cm) kg	1750	2000	2250	2500
Gewicht der Packerversion (Ø 57 cm) kg	1950	2200	2450	2740



# KREISELEGGEN





# IONIO



20-40 CV



	IONIO 90	IONIO 110	IONIO 130	IONIO 150	IONIO 170
Arbeitsbreite (cm)	87	107	127	147	167
Arbeitstiefe (cm)	21	21	21	21	21
Anzahl der Werkzeuge	4+4	6+4	6+6	8+6	8+8
Gewicht der Kufenversion (kg)	195	225	240	275	305
Gewicht der Stabversion (Ø 32 cm) kg	215	250	275	305	33
Gewicht der Zinkenversion (Ø 45 cm) kg	-	245	285	315	335
Gewicht der Netzversion (Ø 42 cm) kg	265	290	315	335	385
Gewicht der Packerversion (Ø 37 cm) kg	260	290	325	335	390

# TIRRENO



25-70 CV



	TIRRENO 90	TIRRENO 110	TIRRENO 130	TIRRENO 150	TIRRENO 170	TIRRENO 190	TIRRENO 210	TIRRENO 230
Arbeitsbreite (cm)	90	110	130	150	170	190	210	230
Arbeitstiefe (cm)	26	26	26	26	26	26	26	26
Anzahl der Werkzeuge	4+4	6+4	6+6	8+6	8+8	10+8	10+10	12+10
Gewicht der Stabversion (Ø 32 cm) kg	275	305	355	380	405	435	465	490
Gewicht der Zinkenversion (Ø 45 cm) kg	/	305	350	385	415	460	485	515
Gewicht der Spiralversion (Ø 38 cm) kg	/	/	/	/	/	480	505	530
Gewicht der Netzversion (Ø 42 cm) kg	285	335	385	425	455	500	550	580
Gewicht der Packerversion (Ø 37 cm) kg	325	355	385	415	445	485	535	570



# ADRIATICO



40-110 CV



	ADRIATICO 110	ADRIATICO 130	ADRIATICO 150	ADRIATICO 180	ADRIATICO 205	ADRIATICO 230	ADRIATICO 250	ADRIATICO 30
<b>Arbeitsbreite (cm)</b>	106	130	154	178	201	225	248	295
<b>Arbeitstiefe (cm)</b>	29	29	29	29	29	29	29	29
<b>Anzahl der Werkzeuge</b>	4+4	4+6	6+6	8+6	8+8	10+8	10+10	12+1
<b>Gewicht der Stabversion (Ø 43 cm) kg</b>	510	550	590	630	670	720	765	860
<b>Gewicht der Zinkenversion (Ø 48 cm) kg</b>	510	550	590	640	690	740	790	830
<b>Gewicht der Spiralversion (Ø 47 cm) kg</b>	/	/	600	650	693	790	830	880
<b>Gewicht der Netzversion (Ø 41 cm) kg</b>	/	/	710	765	825	868	933	/
<b>Gewicht der Packerversion (Ø 48 cm) kg</b>	505	570	660	725	780	845	920	960

# ARTICO



80-120 CV



	ARTICO 250	ARTICO 300
Arbeitsbreite (cm)	248	295
Arbeitstiefe (cm)	29	29
Anzahl der Werkzeuge	10+10	12+12
Gewicht der Stabversion (Ø 43 cm) kg	890	985
Gewicht der Zinkenversion (Ø 48 cm) kg	905	995
Gewicht der Spiralversion (Ø 47 cm) kg	980	1060
Gewicht der Packversion (Ø 48 cm) kg	1040	1150



# INDIANO



80-150 CV



	INDIANO 300	INDIANO 360	INDIANO 400
Arbeitsbreite (cm)	314	361	408
Arbeitstiefe (cm)	28	28	28
Anzahl der Werkzeuge	12+12	14+14	16+16
Gewicht der Stabversion (Ø 43 cm) kg	1315	1480	1645
Gewicht der Zinkenversion (Ø 48 cm) kg	1335	1500	1675
Gewicht der Spiralversion (Ø 47 cm) kg	1405	1585	1760
Gewicht der Packerversion (Ø 48 cm) kg	1480	1685	1895

# ATLANTICO



120-230 CV



	ATLANTICO 400	ATLANTICO 450	ATLANTICO 500
Arbeitsbreite (cm)	408	455	502
Arbeitstiefe (cm)	28	28	28
Anzahl der Werkzeuge	16+16	18+18	20+20
Gewicht der Stabversion (Ø 49 cm) kg	1990	2080	2170
Gewicht der Zinkenversion (Ø 55 cm) kg	2075	2155	2230
Gewicht der Spiralversion (Ø 47 cm) kg	2095	2175	2250
Gewicht der Packerversion (Ø 48 cm) kg	2155	2300	2425





A background of a network diagram with grey nodes and lines on a light grey gradient. The text is centered and reads:

**A NAME  
YOU CAN  
TRUST**



**BERTI MACCHINE AGRICOLE SPA**

Via Musi 1/A-3-4

37042 Caldiero (Verona) - Italy

+39 045 61 39 711

**[bertima.it](http://bertima.it)**

[info@bertima.it](mailto:info@bertima.it)

follow us:

