



B/WINGS



BERTI MACCHINE AGRICOLE SPA
 Via Musi 1/A-3-4
 37042 Caldiero (Verona) - Italy
 +39 045 61 39 711

bertima.it
info@bertima.it

Follow us:





BERTI[®]
A name you can trust

NEW
B/WINGS

THE ULTIMATE SOLUTION FOR OPEN FIELD MAINTENANCE

ENGLISH

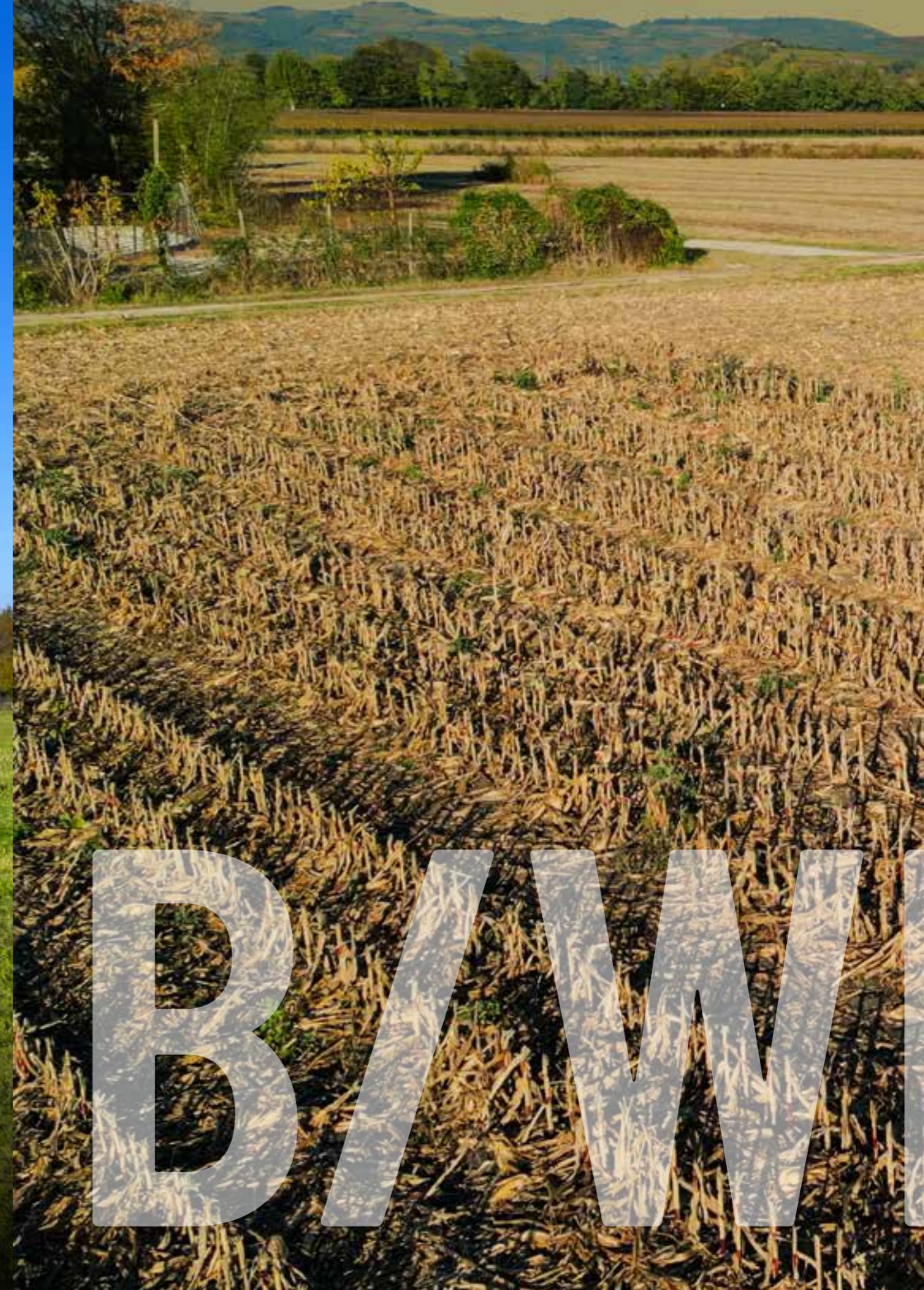

B/WINGS

NEW

B/WINGS

THE ULTIMATE SOLUTION FOR OPEN FIELD MAINTENANCE

B/WINGS represents the evolution of mulching systems for large areas. It consists of two rear folding shredders combined with a third front-mounted shredder, ensuring wide, uniform, and highly productive working coverage.

Designed for open-field operations, B/WINGS is ideal for managing uncultivated land, cover crops, and set-aside areas, where effective and continuous shredding is required even on uneven terrain.

The range includes working widths from 8.00 to 8.80 meters, achieved

with shredding heads of 2.80 and 3.00 meters, configurable according to operational needs and available power.

It can be paired with tractors from 250 to 350 HP.

Unlike other solutions on the market, B/WINGS features a lateral displacement of the rear shredding heads up to 25 cm, allowing adjustment of the working position according to terrain conditions or tractor configuration.

This feature allows variation of overlap and ensures uniform

shredding even near field edges or on uneven ground.

Structural strength, efficiency, and productivity come together in a single machine designed for those who need

to work large areas with maximum performance and the proven reliability that has always distinguished the Berti brand.



TECHNICAL SPECIFICATIONS

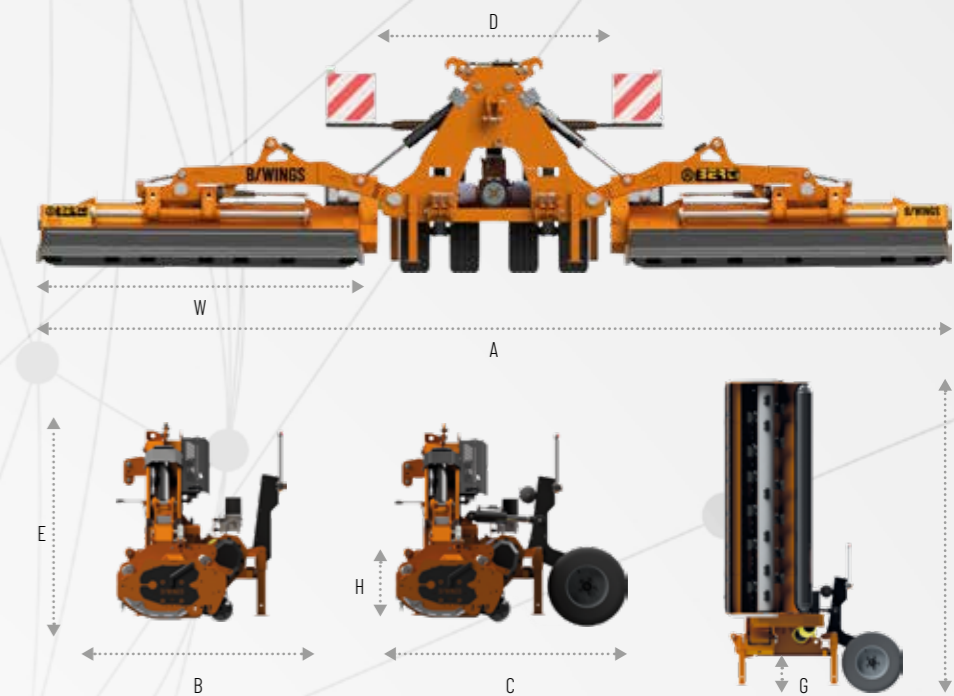

	B/WINGS 840		B/WINGS 880			B/WINGS 840		B/WINGS 880	
HP	250 - 350		250 - 350		A (cm) min-max	800 - 840		840 - 880	
W (cm)	280 + 280		300 + 300		B (cm)	176		176	
Hydr. side-shift mulchers (mm)	250	250	250	250	C (cm)	218		218	
Hammers "A"	26+26		28+28		D (cm) min-max	237 - 287		237 - 287	
Belts	5+5		5+5		E (cm)	176		176	
PTO	1000		1000		F (cm)	383		403	
H (cm)	55		55		G (cm)	45		45	
Weight without Wheels (kg)	4100		4300		Weight with Wheels (kg)	4600		4800	